

M A G N E T I C D R I V E P U M P S

MPC 042 - MPP 031

Operating principle

The distinctive feature of magnetic drive pump is the absence of a connection between motor and pump.

The rotation of the impeller is obtained by the magnetic force between two magnets : one is coupled to the motor, the other drives the impeller.

This construction guaranties the highest reliability and avoids any leakage, so maintenance interventions are reduced and simplified.

The materials used are:

- Polypropylene and PVDF for plastic components.
- Ceramics (Al₂O₃ 99,7%) for shaft and thrust ring.
- Rulon for bearings
- EPDM or Viton for the O-ring.

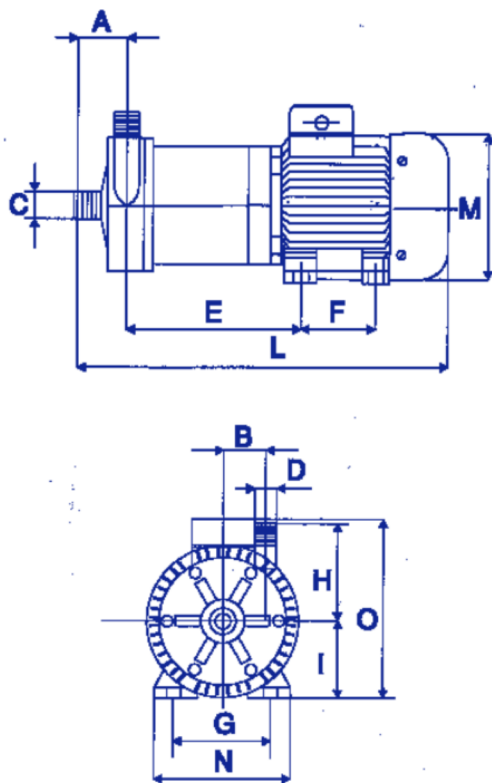
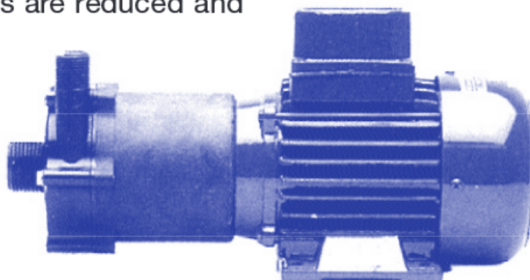

MODEL MPC 042 - MPP 031

A	38	34
B	36	30
C	1"	1/2"
D	1/2"	1/2"
E	109	115
F	71	71
G	90	90
H	72	63
I	56	56
L	280	279
M	110	110
N	107	112
O	128	150
WATT	120	90
PHASES	1	1-3
Rpm	2800/3450	2800/3450
KG	3,450	2,850

MPC 042 - MPP 031

M A G N E T I C D R I V E P U M P S

DIRECTIVES:

- The pump should never run dry.
- Dirty liquids and crystals reduce the life of the bearings.
- The ambient temperature should be between 0 and 40 °C.
- Flame proof motors should be used in explosive atmospheres.
- The liquid should not crystallize in the pump.
- The maximum temperature of the pumped liquid should be: 70 °C (for PP) 95 °C (for PVDF)
- The pump is normal priming.

MPC 042 - MPP 031

50Hz

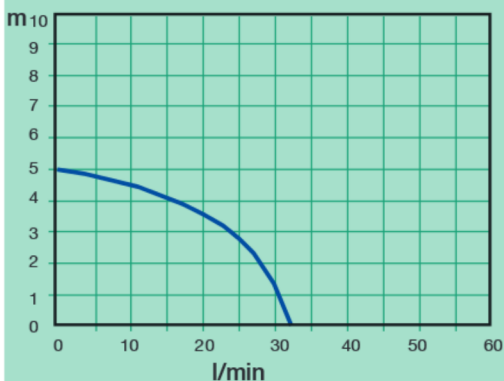

MPC 042 - MPP 031

60Hz

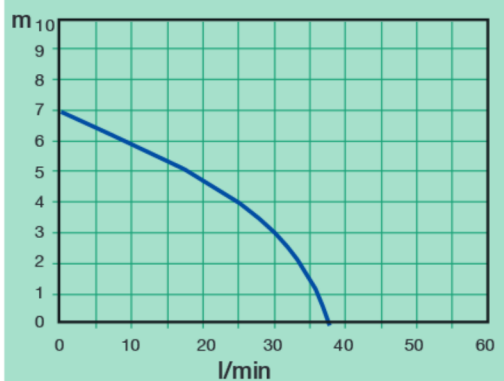

EXPLODED VIEW MAGNETIC DRIVE PUMP

MPC 042

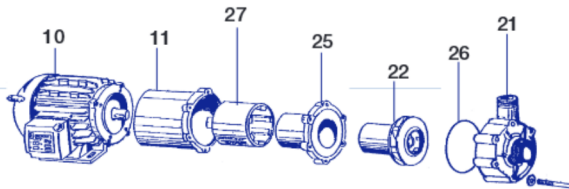

- | | |
|-----------------|----------------|
| 10 Motor | 22 Impeller |
| 11 Flange | 26 O-ring |
| 27 Drive magnet | 21 Pump casing |
| 25 Rear casing | |

Wet-end:
21+22+25+26 = 30

MPP 031

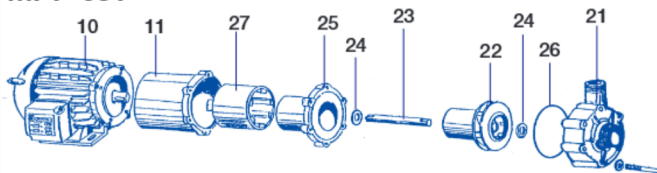

- | | |
|-----------------|----------------|
| 10 Motor | 23 Shaft |
| 11 Flange | 22 Impeller |
| 27 Drive magnet | 26 O-ring |
| 25 Rear casing | 21 Pump casing |
| 24 Thrust | |

Wet-end:
21+22+23+24+25+26 = 30

Curve references:
water at ambient temperature