

M A G N E T I C D R I V E P U M P S

MPA 23/11 - MPA 41/31

Operating principle

The distinctive feature of magnetic drive pump is the absence of a connection between motor and pump.

The rotation of the impeller is obtained by the magnetic force between two magnets : one is coupled to the motor, the other drives the impeller.

This construction guaranties the highest reliability and avoids any leakage, so maintenance interventions are reduced and simplified.

The materials used are:

- Polypropylene and PVDF for plastic components.
- Ceramics (Al₂O₃ 99,7%) for shaft and thrust ring.
- Rulon for bearings
- EPDM or Viton for the O-ring.

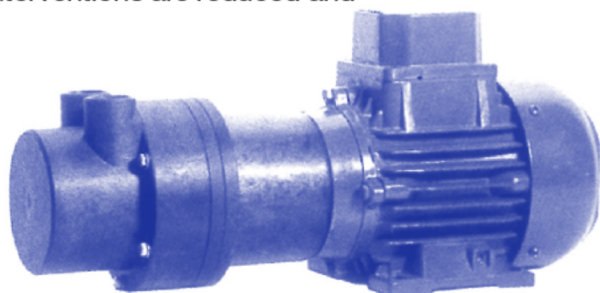

SELFPRIMING

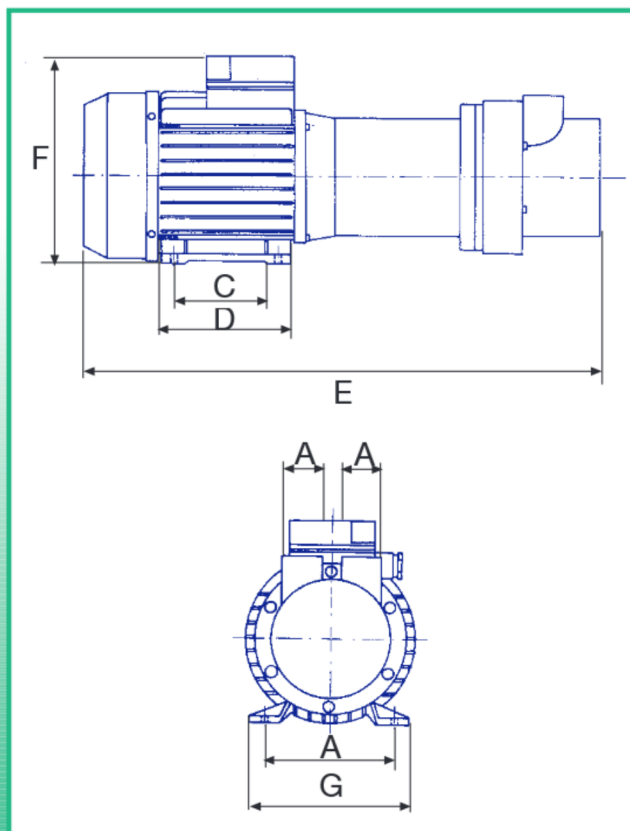

MODEL	MPA 23/11 - MPA41/31	
A	1/2"*	3/4"*
C	71	90
D	90	113
E	325	435
F	128	150
G	90	112
H	112	136
WATT	120	750
PHASES	1-3	1/3
Rpm	2800/3450	2800/3450
KG	4,300	9,200

* Female

MPA 23/11 - MPA 41/31

M A G N E T I C D R I V E P U M P S

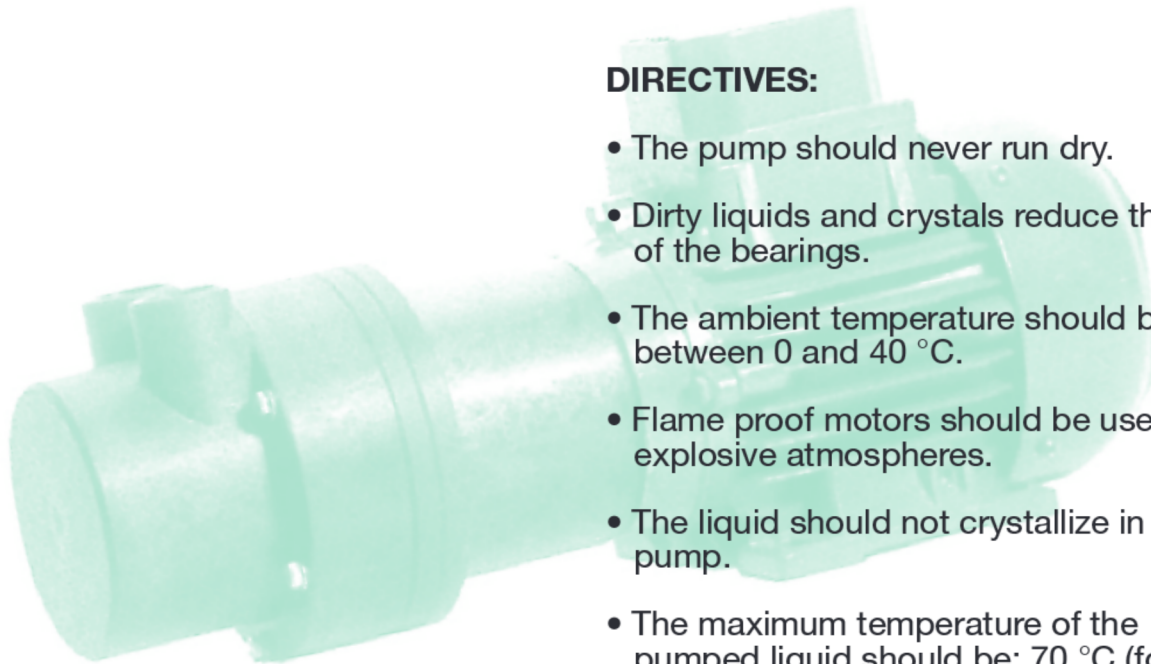

DIRECTIVES:

- The pump should never run dry.
- Dirty liquids and crystals reduce the life of the bearings.
- The ambient temperature should be between 0 and 40 °C.
- Flame proof motors should be used in explosive atmospheres.
- The liquid should not crystallize in the pump.
- The maximum temperature of the pumped liquid should be: 70 °C (for PP) 95 °C (for PVDF)
- The pump is self priming.

MPA 23/11 - MPA 41/31

50Hz

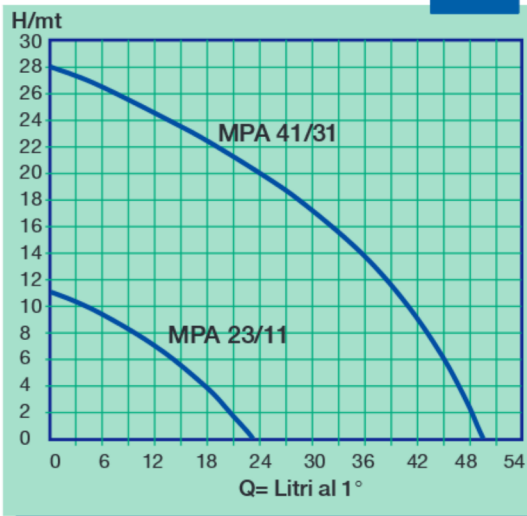

EXPLODED VIEW MAGNETIC DRIVE PUMP

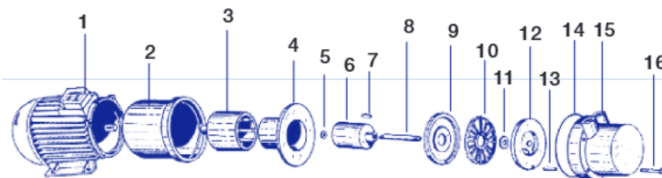

1 Motor	6 Impeller magnet	12 Counter flange
2 Flange	7 key	13 Key
3 Drive magnet	8 Shaft	14 O-ring
4 Rear casing	9 Flange	15 Front casing
5 Thrust ring	10 Impeller	16 Screw
	11 Thrust ring	

Curve references:
water at ambient temperature