



ADVANTAGES

- Accidentally dry run capability with carbon impeller bearing
- Energy saving

FEATURES

- Seal less magnetic drive coupling
- Tmax exercise: PP 80°C - PVDF 98°C
- Connections:
 - socket union for rigid piping connection with PP, PVC, PVDF union ends choice
 - hose barb for hose connetcions
 - flanged

APPLICATION FIELDS

- Acid and alkaline soutions with minimal solid suspended partides
- Electroplating, Chemical and PCB industry

SPECIFICATIONS

	Flow Rate max (l/min.)	Head max (m)	Motor (kw)	IN/OUT D (mm)	T max (°C)	Weight* (kg)
50 Hz	270	15	0,70	50 x 40	PP: 80	PP: 10,50
60 Hz	275	17	0,70	50 x 40	PVDF: 98	PVDF: 11,00

* It depends on the motor

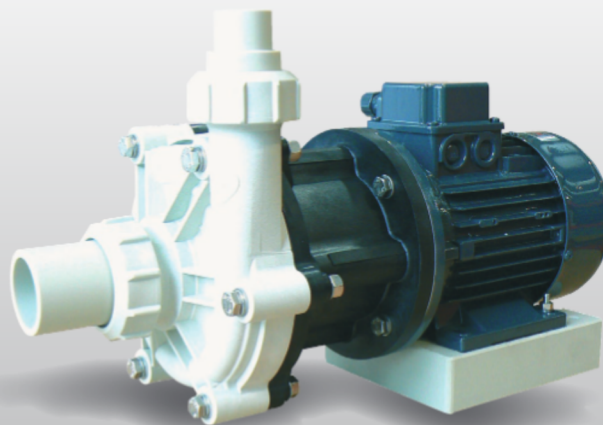

CONNECTION TYPE B

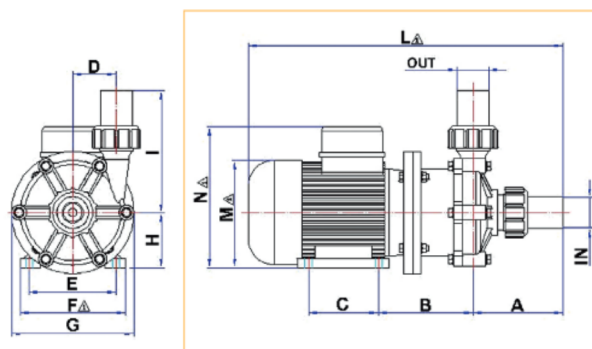

CONNECTION TYPE P

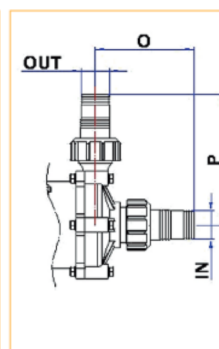

CONNECTION TYPE F

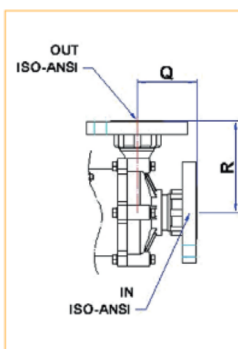

Dimensions:

Mod.	A	B	C	D	E	F Δ	G	H	I	L Δ	M Δ	N Δ	O	P	Q	R	IN	OUT
EVT15	108,0	174,0	90	65	112	136	195	71	155	446	137	170	153,0	210	67,0	125	50	40

Δ It changes according with motor supplier

PUMP IDENTIFICATION

Model	Pump body	Impeller	Shaft	Impeller bearing	O-Ring	Connections	Motor /rpm
EVT 15	P = PP F = PVDF	P = PP F = PVDF	C = Ceramic S = SIC	T = PTFE G = Carbon C = Ceramic	E = EPDM V = Viton	B = Socket union F = Flanged P = Hosebarb	A = 50 Hz / 2800 B = 60 Hz / 3400
EVT 15	P	P	C	G	E	B	A

EVT - Pumps have dry run accidentally capability when equipped with carbon impeller bearing

Performance Curve 50 Hz - Rpm 2800

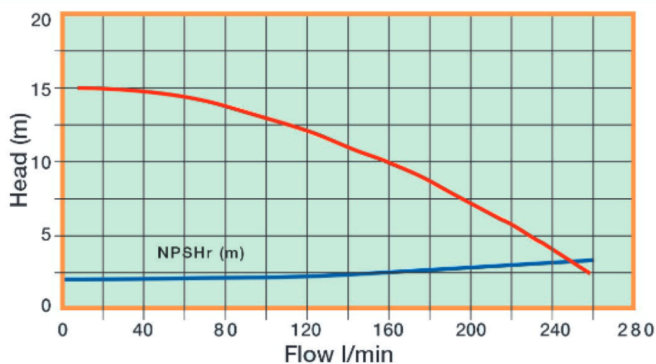

Performance Curve 60 Hz - Rpm 3400

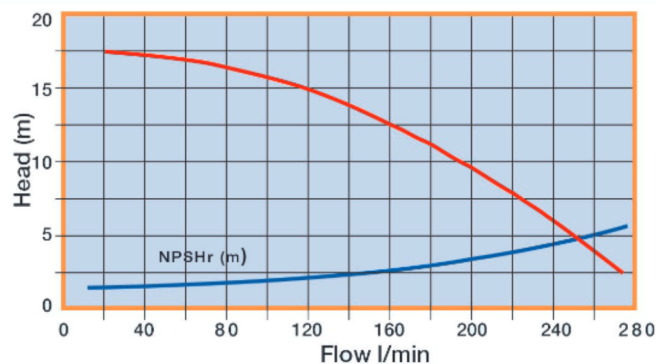

Curves refer to water T = 20°C

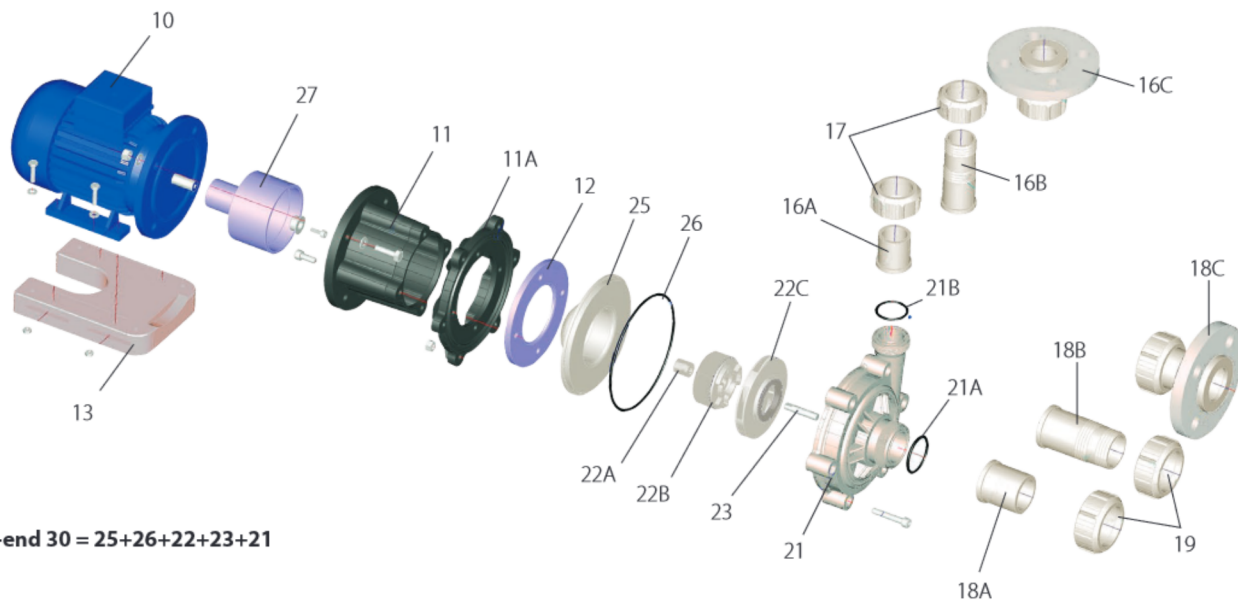

Wet-end 30 = 25+26+22+23+21

- | | | |
|----------------------------|--------------------------|------------------------|
| 10 Motor | 17 Discharge nut | 22 Impeller assembly |
| 11 Bracket | 18A Rigid piping suction | 22A Impeller bearing |
| 11A Flange bracket | 18B Suction hosebarb | 22B Impeller magnet |
| 12 Centering ring | 18C Suction flange | 22C impeller |
| 13 Base plate | 19 Suction nut | 23 Shaft |
| 16A Rigid piping discharge | 21 Pump housing | 25 Rear casing |
| 16B Discharge hosebarb | 21A Suction O-Ring | 26 Pump housing O-Ring |
| 16C Discharge flange | 21B Discharge O-Ring | 27 Drive magnet |

LAFONTE.EU may modify data any time, without notice, in order to get product enhancement